

# 9. Vitrinas Supermarket Supermarket Cases

## HONGOS

Los hongos desempeñan un papel fundamental en la biodiversidad de los ecosistemas forestales y en la mitigación de del impacto del cambio climático.

## FUNGI

Fungi play a fundamental role in the biodiversity of forest ecosystems and in mitigating the impact of climate change.

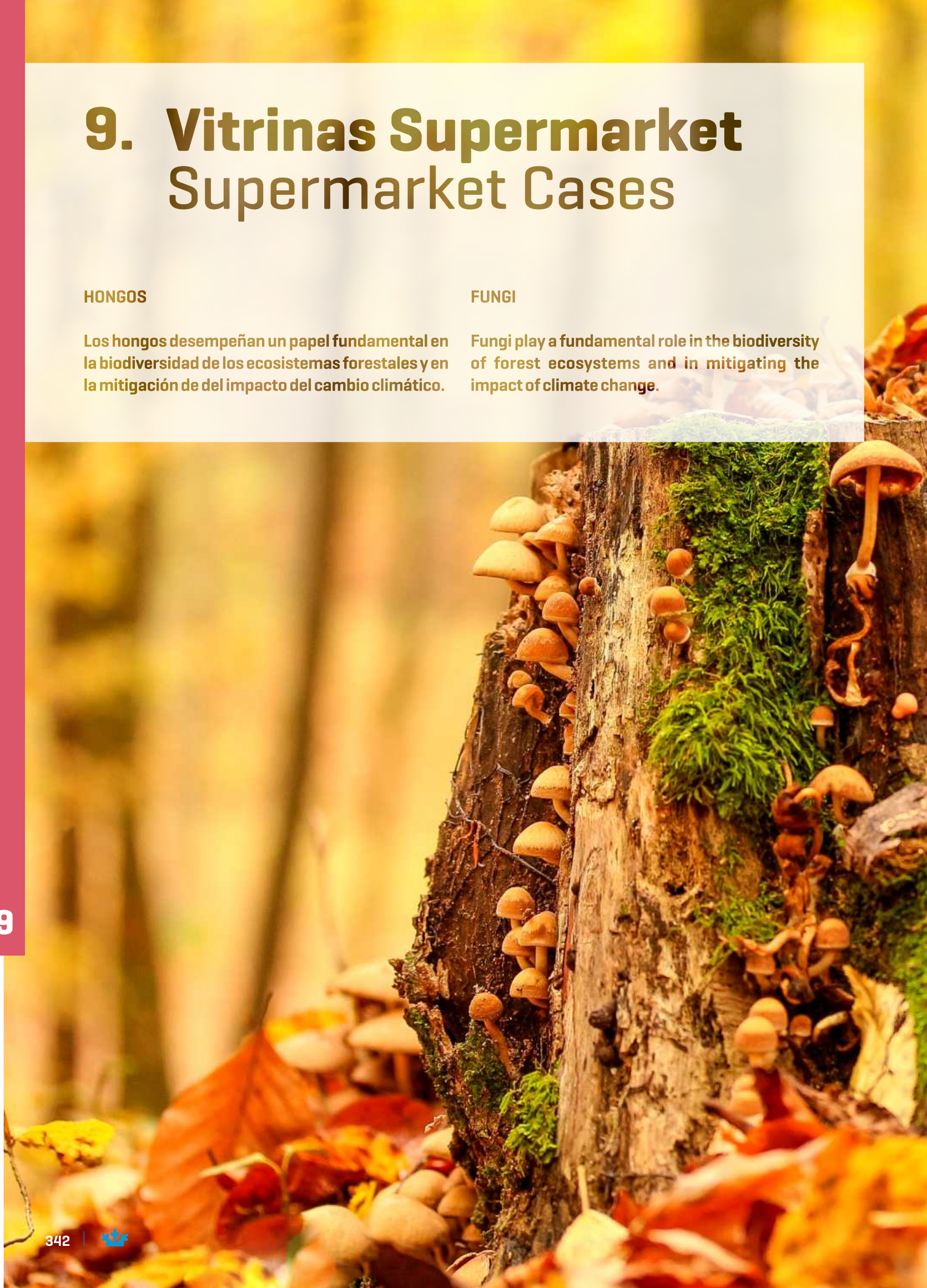



V. SUPERMARKET  
SUPERMARKET CASES



# Vitrinas promocionales

## Promotional cases



9

Serie  
**VALENCIA**  
Series



V. SUPERMARKET  
SUPERMARKET CASES



# Vitrinas promocionales



Serie  
**VALENCIA**  
Series

## CARACTERÍSTICAS TÉCNICAS



### Comprobación de fuga de gas

Todos las unidades condensadoras son **comprobados al 100%, en cámara de Helio** para la detección de la fuga de gas.

## TECHNICAL CHARACTERISTICS

### Leak detection system

All condenser units are **tested 100%, in helium** chambers to refrigerant leak detections.

VVL 12



### Opcional / Optional

Illuminación LED VVL 3000K  
LED Lighting VVL 3000K

9

MOD.



Potencia  
Power  
(W)



Capacidad  
Capacity  
(L)



Superficie exposición  
(m<sup>2</sup>)



Compresor  
Compressor  
(HP)



Consumo  
Consumption  
(kWh/24h)



Potencia  
frigorífica  
Cooling capacity  
(W A -10°C)

123

Control



Refrigerante  
Coolant

VVL 12

1110

180

1,05

3/4

11,8

915

Digital

R-290

Fotografías no contractuales / Non contractual pictures.

Características técnicas y constructivas sujetas a variación sin previo aviso / We reserve the right to change specifications without prior notice.

Los datos técnicos están sujetos a posibles variaciones que serán actualizadas periódicamente en las fichas técnicas del producto, disponibles en la web.  
The technical data are subject to possible variations that will be updated periodically in the technical data sheets of the product, which are available on the website.



# Promotional cases

Serie  
**VALENCIA**  
Series

## REFRIGERACIÓN



### Refrigeración

Sistema de **Condensación Ventilada**.

Sistema de **Evaporación Forzada**.

Desescarche por **gas caliente**.

## REFRIGERATION

### Refrigeration

**Ventilated condensation** system.

**Forced evaporation** system.

**Hot gas** defrost.

VVL 12

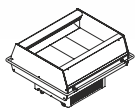

VVL 12

1260 x 1170 x 900 mm.  
Temp. 0°C/+2°C  
C. Clima. 3  
230v/1 ph/50 Hz



**Vitrina inclinable**  
Tilting display case

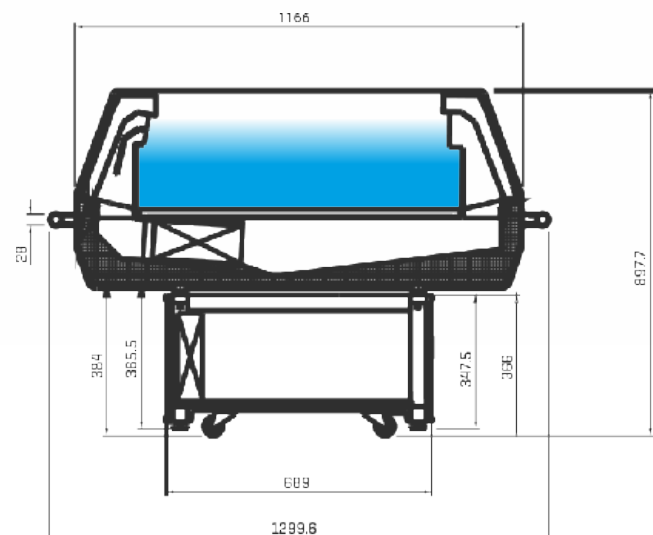

VVL

