

Project: _____

Location: _____

Item #: _____ Quantity: _____

Model: _____

MODELS: VBC9R VBC12R VBC15R VBC18R VBC25R *Barcelona series- Refrigerated modular display case.*



VBC15R



VBC15R

Strengths

- ✓ **Combination of different cooling system modules: ventilated, half-static and static. Modules with or without cooled storage. Angles and counters to adapt the line to a space.**
- ✓ **Greater precision in temperature control. Easier to adjust the temperature range we want to achieve.**
- ✓ **All condenser units are tested 100%, in helium chambers to refrigerant leak detections.**
- ✓ **LED lighting incorporated, reducing energetic consumption between 80% and 90% respect to a traditional light bulb.**
- ✓ **Infrico is AENOR audited and certified by internationally recognized firm. ISO 9001:2015 (Quality); ISO 14001:2015 (Environmental); OSHAS 18001:2007 (Prevention and Worker Safety). Audited and Certified by INTERTEK for compliance with UL 471 and NSF 7.**

MODEL	Dimensions (mm)			Sides thickness (mm)	Nº Doors	Exposure surface (m ²)	Cabinet volume (L)	Gross volume (L)	Temp. regime (°C)	Ref.	Net weight (Kg.)
	Length	Depth	Height								
VBC9R	938	1150	1290	30 + 30	1	0,52	131	1392	0°C/+6°C	R452	154
VBC12R	1250	1150	1290	30 + 30	2	0,59	175	1854	0°C/+6°C	R452	154
VBC15R	1562	1150	1290	30 + 30	2	0,87	219	2317	0°C/+6°C	R452	186
VBC18R	1875	1150	1290	30 + 30	3	1,04	263	2782	0°C/+6°C	R452	206
VBC25R	2500	1150	1290	30 + 30	4	1,39	350	3709	0°C/+6°C	R452	230

Revision: 01 Fecha: 25/09/2018

WE RESERVE THE RIGHT TO CHANGE SPECIFICATIONS WITHOUT PRIOR NOTICE



Infrico
 Ctra. de Aguilar A-318 por Moriles
 km. 15,5 - A-3132
 14900 Lucena (Córdoba)
 Spain

www.infrico.com
 info@infrico.com
 Tel. 00 34 957 51 03 03
 Fax. 00 34 957 51 03 04

APPROVALS:

AVAILABLE AT:



MODELS: VBC9R VBC12R	VBC15R VBC18R	VBC25R	Barcelona series- Refrigerated modular display case.
---------------------------------	--------------------------	---------------	---

STANDARD FEATURES

➤ **Modular line**

- Different cooling system modules can be combined using complete dividers.
- Designed for meat and precooked and packaged foods, charcuterie, milk products and sandwiches.

➤ **Exterior**

- Plastic coated steel exterior.
- AISI 304 stainless steel worktop.
- AISI 304 stainless steel exposure surface.
- Lacquered DM decoration.
- Folding secured curved glass.

➤ **Interior**

- Plastic coated steel interior.
- Enamelled steel base.
- LED lighted middle shelf and exposure surface.
- Storage door clearance of 425x255 mm.

➤ **Insulation**

- Insulation by free CFC's polyurethane, foam high-pressure injected with density 40 Kg/m.
- Zero ODP and Low GWP.

➤ **Refrigeration**

- Temperature and defrost regulated by a digital controller.
- Automatic defrost.
- Ventilated condensation system.
- Forced evaporation system.
- Stainless steel evaporative tray with double vat, one for hot gas and another with electrical heater.
- Climatic class 4 (30°C, 55%RH).

➤ **Electrical**

- Electrical connection: 230 V / 1 ph / 50 Hz. 

OPTIONAL

- Sliding back doors.
- Night curtains.
- Heated glass.
- Range of decoration colours (consult).
- Electrical connection 230 V / 1 ph / 60 Hz.
- Electrical connection 115 V / 1 ph / 60 Hz.

MODEL	Dimensions palletizing (mm)			Pallet weight (Kg.)	Power (W)	Comp. (HP)	Cooling power (W at -10°C)	Consumption (kWh/24h)	Container 20'/40'/40'HC	Trailer
	Length	Depth	Height							
VBC9R	1100	1200	1500	190	755	1/2	817	10,6	10 / 20 / 20	24
VBC12R	1340	1200	1520	200	1015	5/8	1096	14,2	4 / 9 / 9	20
VBC15R	1700	1200	1510	230	1070	3/4	1315	15,0	4 / 9 / 9	15
VBC18R	2015	1200	1550	255	1310	1	1506	18,3	4 / 9 / 9	13
VBC25R	2650	1200	1515	410	1585	1 + 1/6	2009	22,2	2 / 4 / 4	10

WE RESERVE THE RIGHT TO CHANGE SPECIFICATIONS WITHOUT PRIOR NOTICE



Infrico
 Ctra. de Aguilar A-318 por Moriles
 km. 15,5 - A-3132
 14900 Lucena (Córdoba)
 Spain

www.infrico.com
 info@infrico.com
 Tel. 00 34 957 51 03 03
 Fax. 00 34 957 51 03 04

APPROVALS: _____

AVAILABLE AT: _____



MODELS: VBC9R VBC12R VBC15R VBC18R VBC25R *Barcelona series- Refrigerated modular display case.*

GENERAL VIEW

FRONT VIEW



TOP VIEW

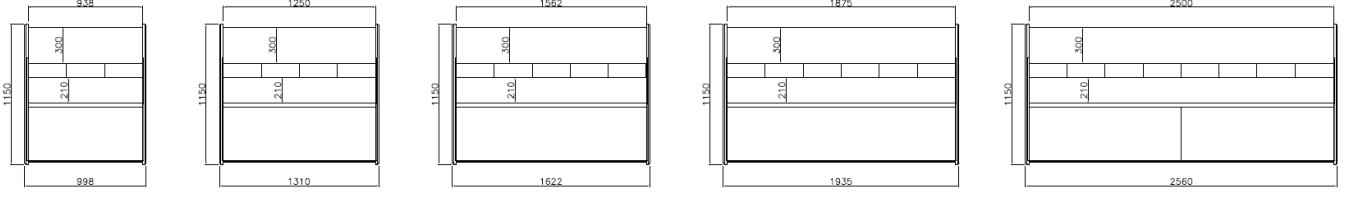

VBC9R

VBC12R

VBC15R

VBC18R

VBC25R

SIDE VIEW

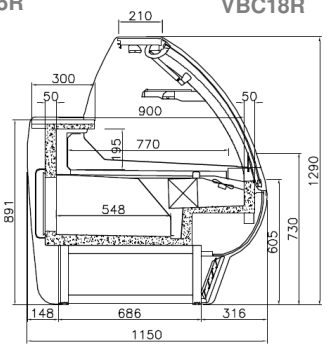

CONNECTIONS

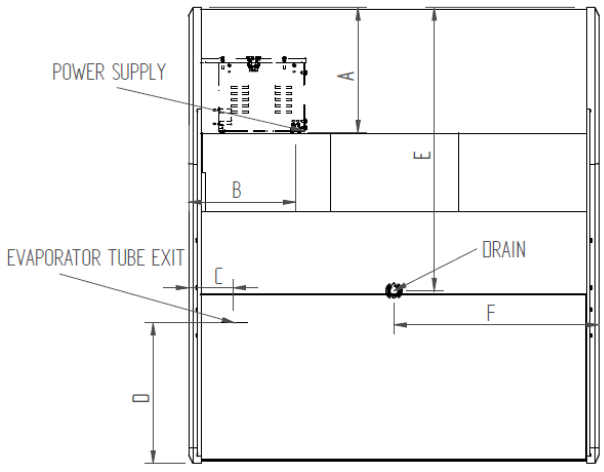

MODEL	A (mm)	B (mm)	C (mm)	D (mm)	E (mm)	F (mm)
VBC9R	303	260	108	341	687	500
VBC12R	303	260	108	341	687	625
VBC15R	303	260	108	341	687	781
VBC18R	303	260	108	341	687	938
VBC25R	303	260	108	341	687	1250

Revision: 01 Fecha: 25/09/2018