

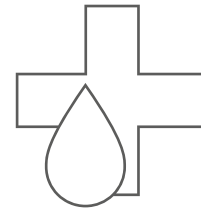

# HEALTH CARE



El almacenamiento seguro de productos de gran valor como la sangre o el concentrado de hematíes es imprescindible en la medicina.

Presentamos nuestra gama de equipos de refrigeración para bancos de sangre, teniendo como principales objetivos la confiabilidad, seguridad y la facilidad de uso. Mantienen una temperatura interna homogénea de +2°C a +6°C. Para ello, hemos diseñado nuestros equipos de acuerdo a la norma **DIN 13277** por lo que incorporan una serie de mejoras tendentes a asegurar la conservación de las bolsas de sangre.

Safe storage for high-value products such as blood or concentrated red blood cells is essential in medicine.

We present our range of refrigeration equipment for blood banks, with the main objective being the reliability, safety and easy use. They are designed to maintain a homogeneous internal temperature of +2°C to +6°C. For that purpose, we have incorporated a series of improvements aimed at ensuring the preservation of blood bags and in compliance with **DIN 13277**.

## DIN 13277

### La norma DIN 13277 marca los siguientes requisitos:

- Temperatura de operación entre +2°C y +6°C
- Temperatura ambiente del lugar de instalación admitida entre +10°C y +35°C
- Monitorización de la temperatura interior [+4°C]
- Fácil limpieza y desinfección de la cámara
- Capacidad de carga mecánica de las piezas montadas uniforme de 100kg/m<sup>2</sup>
- Puertas dotadas de cerraduras
- Alarma en caso de fallo de corriente durante un mínimo de 12 h
- Sistema de alarma óptica y acústica en caso de desviación de la temperatura por encima de +6°C y por debajo de +2°C
- Contacto libre de potencial para transmisión de alarma
- Dispositivo de seguridad para prevenir que las bolsas de sangre se enfríen por debajo de +2°C

### DIN 13277 sets the following requirements:

- Operating temperature range from +2°C to +6°C
- Interior room temperature at the installation site is accepted between +10°C and +35°C
- The interior temperature is monitored [+4°C]
- Interior is easy to clean and disinfect; water resistant and with corrosion protection
- Drawers are able to withstand uniform loads of 100 kg/m<sup>2</sup>
- Doors fitted with locks
- Power failure alarm for a minimum of 12h
- Acoustic / visual alarm signal in case of temperature deviations, if temperature values are higher than +6°C or lower than +2°C
- Potential free contact for alarm transmission
- Safety device to prevent the temperature of blood bags going below +2°C



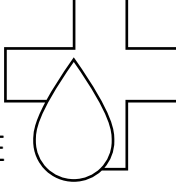

## BANCOS DE SANGRE / BLOOD BANKS

**NUESTRA AMPLIA EXPERIENCIA EN FABRICACIÓN DE EQUIPOS DE FRÍO A NIVEL MUNDIAL Y CUMPLIENDO CON LAS ESPECIFICACIONES O REQUERIMIENTOS DE CALIDAD DE DIFERENTES MERCADOS, HACE QUE PUEDES CONFIAR EN INFRICO MEDCARE.**

El compromiso de Infrico Medcare con la seguridad es máximo, por ello nuestros equipos refrigeradores para bancos de sangre han sido acreditados por un sistema de gestión de la calidad basado en la norma **UNE-EN ISO 13485:2016** de productos sanitarios.

Además, todos nuestros equipos han superado los ensayos de equipos electromédicos según las normas **EN 60601-1** y **EN 60601-1-2**

**OUR EXTENSIVE EXPERIENCE AS A WORLDWIDE MANUFACTURER OF COOLING EQUIPMENT AND THE SPECIFICATIONS OR QUALITY REQUIREMENTS OF DIFFERENT MARKETS THAT WE COMPLY WITH, ENSURES YOU CAN RELY ON INFRICO MEDCARE.**

The commitment of Infrico Medcare with safety of its products is the main objective. Therefore, all blood bank refrigerators have been accredited by a quality management system based on the **ISO 13485:2016** of medical devices.

In addition, all our equipment have passed the test of electromedical equipment according to standards **EN 60601-1** and **EN 60601-1-2**.

### GAMA HEALTH CARE PLUS

La gama Health CARE PLUS de nuestros equipos para bancos de sangre está diseñada de acuerdo a la **DIN 13277**, teniendo en cuenta la sensibilidad del producto almacenado y garantizando su seguridad. Ofrece modelos desde los 183L a los 1202L, disponibles con puertas ciega o de cristal y con el interior en acero inoxidable.

### HEALTH CARE PLUS SERIES

The Health CARE PLUS series of our blood bank equipment is designed in agreement with **DIN 13277**, taking into account the sensitivity of the stored product and ensuring its safety. It offers models from 183L to 1202L, available with solid or glass doors and stainless steel interior.



BBMD17S  
183 L

BBMD25S  
251 L

BBMD40S  
398 L

Pág. 42 - 43



BBMD65S  
506 L

BBMD80S  
719 L

BBMD130S  
1166 L

Pág. 44 - 45



BBMD17G  
191 L

BBMD25G  
261 L

BBMD40G  
413 L

Pág. 42 - 43



BBMD65G  
521 L

BBMD80G  
737 L

BBMD130G  
1202 L

Pág. 44 - 45

## CARACTERÍSTICAS GENERALES / GENERAL FEATURES



### CONTROLADOR DIGITAL PLUS

En todos los modelos de la gama Health CARE PLUS

### DIGITAL PLUS CONTROLLER

In all models of Health CARE PLUS series



### CERRADURA / SENSOR DE PUERTA

Todos nuestros equipos disponen de cerraduras y sensores de puerta abierta, para garantizar la seguridad de los productos almacenados, controlando el tiempo de apertura y el funcionamiento de los ventiladores.

### LOCK / DOOR SENSOR

All our equipment has locks and open door sensors, to guarantee the security of the stored products by controlling opening time and fans functioning.



### ILUMINACIÓN LED

El uso de iluminación LED reduce el consumo energético del equipo y mejora la homogeneidad de la temperatura en el interior.

### LED LIGHTING

The use of LED lighting reduces the energy consumption and improves the homogeneity of the temperature inside the cabinet.



### CAJONES FLEXIBLES

Nuestro sistema de cajones con frontales en policarbonato ofrece una total visibilidad del producto almacenado. Permite ajustar la posición de los mismos y variar su número o complementarlos con separadores. Esto proporciona una comodidad en el almacenamiento de bolsas de sangre o sus derivados, ajustando el equipo a sus necesidades.

### FLEXIBLE DRAWERS

Our system of drawers with polycarbonate fronts allows a total visibility of the stored product. Position adjustments and its number variation or the complimenting of divisors are allowed in the system. This provides the fitting of the equipment in accordance to your needs and storage comfort of blood bags or their derivatives.



### ESTILO DE PUERTAS

En todos nuestros equipos existe la posibilidad de elegir entre puerta ciega o de cristal. Todas nuestras puertas son abatibles y reversibles.

### DOOR STYLE

It is possible to choose solid or glass doors in our whole range. All our doors are hinged and reversible.



### BURLETE DE ARPÓN PARA UN CAMBIO RÁPIDO Y FÁCIL

Es ideal para mantener una higiene óptima y para facilitar los trabajos de mantenimiento.

### EASY REMOVABLE DOOR GASKET

It is ideal to maintain optimal hygiene and facilitate maintenance work.



### AMPLIOS RADIOS

Los interiores presentan amplios radios en las esquinas, que facilitan su limpieza.

### ROUNDED CORNERS

The interiors have rounded corners, which facilitate their cleaning.

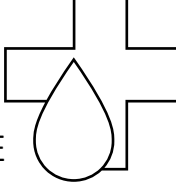

#### SONDA DE SIMULACIÓN DE PRODUCTO

La sonda del controlador viene encapsulada en líquido para simular la temperatura interna del producto.



#### PRODUCT TEMPERATURE SIMULATION PROBE

The controller is equipped with a probe immersed in reference fluid to simulate internal product temperature.

#### INTERIOR EN ACERO INOXIDABLE



#### STAINLESS STEEL INTERIOR



#### SONDA DE REGULACIÓN EN AIRE

Además de la sonda de simulación de producto, los equipos de banco de sangre disponen de una sonda en aire con la que se regula la temperatura del equipo, aumentando la seguridad del mismo.

#### AIR REGULATION PROBE

In addition to the product temperature simulation probe, the blood bank equipment is regulated through an air temperature probe increasing safety in temperature readings.

#### TERMOSTATO DIGITAL ANTICONGELACIÓN

Este dispositivo imposibilita al producto a bajar su temperatura por debajo de +2°C.

#### FREEZING PROTECTION ELECTRONIC CONTROLLER

Safety thermostat prevents the temperature dropping below +2°C.

#### BATERÍA

Permite mantener el registro de temperatura y alarmas en el caso de fallo de alimentación

#### BATTERY

Allows the maintenance of temperature and alarms register in case of a power failure.

#### BANDEJA EVAPORATIVA

Nuestros equipos llevan incorporada una bandeja para evaporar de manera automática el agua del desescarche.

#### EVAPORATION PAN

Our equipment has a built-in tray to evaporate automatically defrosted water.

#### DESESCARCHES AUTOMÁTICOS INTELIGENTES

Nuestros equipos cuentan con desescarche automático, para asegurar una refrigeración uniforme en el tiempo y menos mantenimiento. Además, el equipo analiza su funcionamiento y realiza los desescarches solo cuando es necesario para mejorar la estabilidad de la temperatura.

#### ADVANCED DEFROST SYSTEM

Built-in to ensure uniform cooling over time and to facilitate maintenance. In addition, the equipment analyses its operation and only defrosts when it is necessary, to improve the stability of the temperature.

#### RUEDAS / PATAS REGULABLES / REGULADORES DE ALTURA

En todos nuestros armarios existe la posibilidad de ser equipados con ruedas para facilitar el desplazamiento y la limpieza.

#### CASTERS / ADJUSTABLE LEGS / HEIGHT REGULATORS

In our whole range, there is a possibility to incorporate casters to facilitate displacement and cleaning.







MEDCARE

PHARMA

1

HEALTH

2

LAB

3

4

5

6

7

8



## ARMARIO DE REFRIGERACIÓN HEALTH CARE PLUS / HEALTH CARE PLUS REFRIGERATOR

**DIN 13277**



GAMA SERIES	Health CARE PLUS	Health CARE PLUS	Health CARE PLUS	Health CARE PLUS	Health CARE PLUS	Health CARE PLUS
MODELO MODEL	<b>BBMD17S</b>	<b>BBMD17G</b>	<b>BBMD25S</b>	<b>BBMD25G</b>	<b>BBMD40S</b>	<b>BBMD40G</b>
Rango Tª Temperature range [°C]	+2 / +6					
Capacidad Nominal [litros] Nominal Capacity [litres]	183	191	251	261	398	413
Medidas Exterior [mm] L x P x A Exterior dimensions [mm] W x D x H	670 x 698 x 1293	670 x 698 x 1293	670 x 697 x 1538	670 x 697 x 1538	670 x 683 x 1963	670 x 683 x 1963
Medidas Interior [mm] L x P x A Interior dimensions [mm] W x D x H	568 x 484 x 666	568 x 504 x 666	568 x 484 x 913	568 x 504 x 913	568 x 484 x 1338	568 x 504 x 1338
Claro de puerta [mm] L x A Door opening [mm] W x H	568 x 610	568 x 610	568 x 855	568 x 855	568 x 1280	568 x 1280
Espesor Aislamiento [mm] Insulation thickness [mm]	50					
Acabado Exterior Exterior finishing	Acero galvanizado plastificado blanco White plastic coated galvanised steel					
Acabado Interior Interior finishing	Acero Inoxidable Stainless steel					
Nº Cajones Drawers Number	3	3	4	4	6	6
Dimensiones Cajón [mm] L x P Drawer Size [mm] W x D	497 x 439					
Número de bolsas de sangre Blood bags capacity	132	132	176	176	264	264
Material Cajones Drawers Material	Acero Inoxidable Stainless steel					
Intercambiabilidad de Estantes/Cajones Interchangeable Shelves/Drawers	Si Yes					
Tipo de Puerta Door Type	Ciega Solid	Cristal Glass	Ciega Solid	Cristal Glass	Ciega Solid	Cristal Glass
Cerradura Lock	Si Yes					
Salida USB USB Port	Si Yes					
Datalogger Datalogger	Si Yes					
Batería Battery	Si Yes					
Sonda simulación producto Product temperature simulation probe	Si Yes					
Sonda de temperatura ambiente Interior room temperature probe	Si Yes					
Termostato anticongelación Freezing protection controller	Si Yes					
Tipo de Controlador Controller type	Digital Plus					
Tipo de Refrigerante Refrigerant type	R290					
Potencia Eléctrica [W] Electric power [W]	222	227	222	227	222	241
Tensión/Frecuencia [V / Hz] Voltage/Frequency [V / Hz]	230 / 50					
Peso [kg] Weight [kg]	91	96	119	132	145	156

\* Pruebas realizadas con una temperatura ambiente de +25°C \* Measured at +25°C ambient temperature

Nos reservamos el derecho a modificar las especificaciones técnicas y constructivas sin previo aviso.  
We reserve the right to modify technical and construction specifications without prior notice.

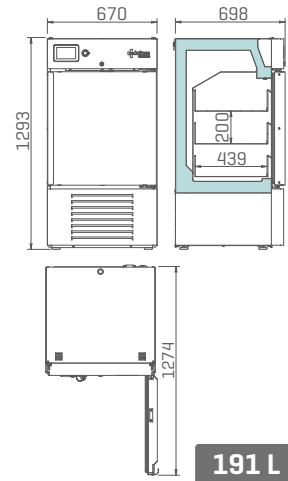
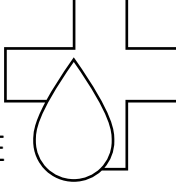

191 L

BBMD17

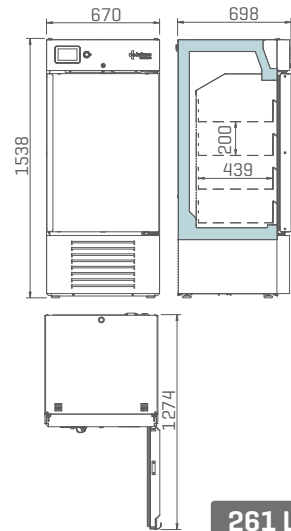

261 L

BBMD25

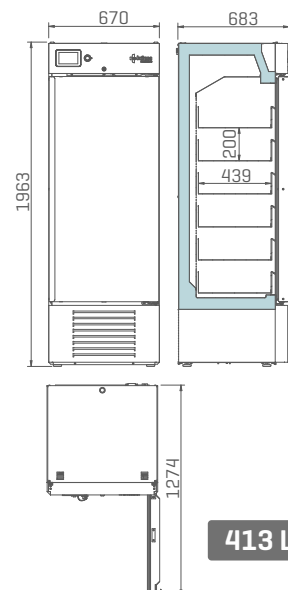

413 L

BBMD40

MEDCARE

PHARMA

1

HEALTH

2

LAB

3

4

5

6

7

8

## ARMARIO DE REFRIGERACIÓN HEALTH CARE PLUS / HEALTH CARE PLUS REFRIGERATOR

**DIN 13277**



GAMA SERIES	Health CARE PLUS	Health CARE PLUS	Health CARE PLUS	Health CARE PLUS	Health CARE PLUS	Health CARE PLUS
MODELO MODEL	<b>BBMD65S</b>	<b>BBMD65G</b>	<b>BBMD80S</b>	<b>BBMD80G</b>	<b>BBMD130S</b>	<b>BBMD130G</b>
Rango T° Temperature range [°C]	+2 / +6					
Capacidad Nominal [litros] Nominal Capacity [litres]	506	521	719	737	1166	1202
Medidas Exterior [mm] L x P x A Exterior dimensions [mm] W x D x H	687 x 870 x 1950	687 x 870 x 1950	797 x 1000 x 1950	797 x 1000 x 1950	1385 x 834 x 1950	1385 x 834 x 1950
Medidas Interior [mm] L x A Interior dimensions [mm] W x H	534 x 633 x 1207	534 x 654 x 1207	644 x 803 x 1389	644 x 823 x 1389	1233 x 681 x 1388	1233 x 702 x 1388
Claro de puerta [mm] Door opening [mm]	534 x 1351		645 x 1351		534 x 1351	
Espesor Aislamiento [mm] Insulation thickness [mm]	75					
Acabado Exterior Exterior finishing	Acero galvanizado plastificado blanco White plastic coated galvanised steel					
Acabado Interior Interior finishing	Acero Inoxidable Stainless steel					
N° Cajones Drawers Number	6	6	6	6	12	12
Dimensiones Cajón [mm] L x P Drawer Size [mm] W x D	453 x 581	453 x 581	564 x 746	564 x 746	453 x 581	453 x 581
N° bolsas de sangre Blood bags capacity	336	336	510	510	672	672
Material Cajones Drawers Material	Acero Inoxidable Stainless steel					
Intercambiabilidad de Estantes/Cajones Interchangeable Shelves/Drawers	Si Yes					
Tipo de Puerta Door Type	Ciega Solid	Cristal Glass	Ciega Solid	Cristal Glass	Ciega Solid	Cristal Glass
Cerradura Lock	Si Yes					
Salida USB USB Port	Si Yes					
Datalogger Datalogger	Si Yes					
Batería Battery	Si Yes					
Sonda simulación producto Product temperature simulation probe	Si Yes					
Sonda de temperatura ambiente Interior room temperature probe	Si Yes					
Termostato anticongelación Freezing protection controller	Si Yes					
Tipo de Controlador Controller type	Digital Plus					
Tipo de Refrigerante Refrigerant type	R290					
Potencia Eléctrica [W] Electric power [W]	272	266	431	425	407	454
Tensión/Frecuencia [V / Hz] Voltage/Frequency [V / Hz]	230 / 50					
Peso [kg] Weight [kg]	173	189	204	219	251	287

\* Pruebas realizadas con una temperatura ambiente de +25°C  
\* Measured at +25°C ambient temperature

Nos reservamos el derecho a modificar las especificaciones técnicas y constructivas sin previo aviso.  
We reserve the right to modify technical and construction specifications without prior notice.

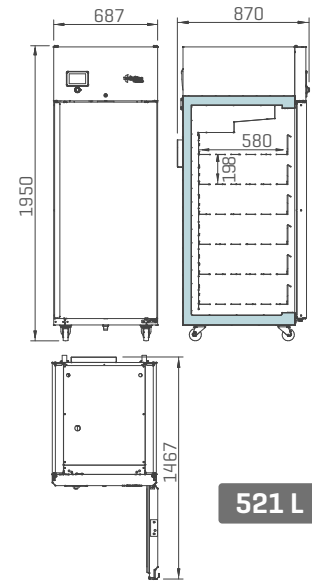
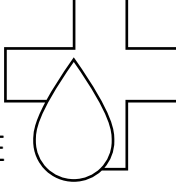

521 L

BBMD65

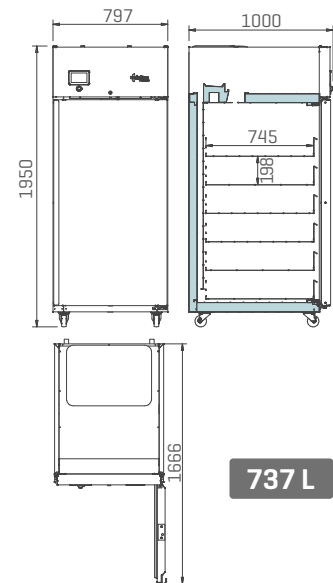

737 L

BBMD80

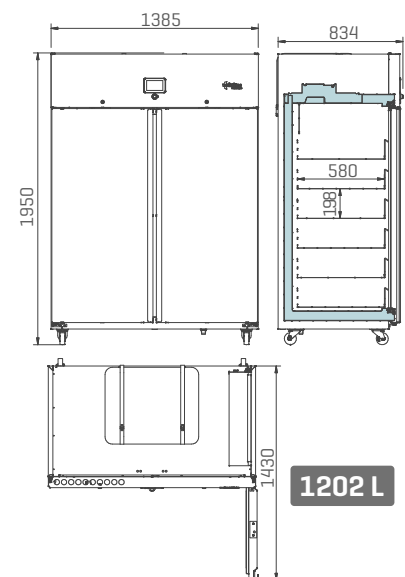

1202 L

BBMD130

MEDCARE

PHARMA

HEALTH

2

LAB

3

4

5

6

7

8